

# USER MANUAL

## EVO17



## **INTRODUCTION**

Thank you for choosing Evotech Performance Industrial Vacuum Cleaner, a high-quality product made by the latest technology. We hope that this device will be to your satisfaction and meet your expectations. We are continuously striving to improve our products in our product segment and will continue to supply the market with new and reliable equipment.

## **NOTICE!**

1. These instructions are only for EVO17 Dust Extractors.
2. The EVO17 Dust Extractors are designed for cleaning construction site. The EVO17 can be connected to small or medium machines such as drills or grinders. The machine is designed for picking up dry, non-flammable dust and debris in an indoor environment. It is not suitable for picking up liquids.
3. Please carefully go through all the safety regulations and safety instructions
4. Read the complete instruction manual before using it.
5. All spare parts and accessories used on this device must be specified by EVOTECH PERFORMANCE.
6. Check before and after use that all the switches are in the OFF position.
7. We recommend cleaning the machine after each use.

## **Environmental protection**

We care about our environment!

All packages are recyclable, please put them in the recycle bin or your nearest recycling centre.

All used or broken machines can be partly recycled, do not dispose any used/broken machines in the open area, talk to your nearest recycle center for more options.

# 1. SAFETY INSTRUCTIONS

When using an electrical appliance, basic precautions should always be followed, including the following:

## **WARNING - To reduce the risk of fire, electric shock or injury:**

- Cables damaged through crushing or splitting can be dangerous if used and should be replaced immediately. Risk of personal injury.
- Make sure the assembly area is firm, so the dust extractor does not tip over. Risk of personal and material injury.
- Risk of pinching when handling the toggle fasteners.
- The machine must not be used in environments where explosive gases may be present. Serious risk of explosion.
- Improper connection of the equipment-grounding conductor can result in a risk of electrical shock. Check with a qualified electrician or service person if you are in doubt as to whether the outlet is properly grounded. Do not modify the plug provided with the machine. If it will not fit the outlet. Have a proper outlet installed by a qualified electrician.
- Before using the machine, make sure that the power & voltage corresponds with the voltage shown on the machine's rating plate.
- Do not leave the machine when plugged in. Unplug the cord from the outlet when not in use and before cleaning or servicing the machine.
- Do not use it outdoors or on a wet surface, this machine is for indoor and dry use only.
- Do not allow to use as a toy. Close attention is necessary when used by or near children.
- Use only as described in this manual. Use only manufacturer's recommended attachments.
- Operators shall be adequately instructed on the use of the machine
- This machine is not intended for use by persons (including children) with reduced physical, sensory or mental capabilities, or lack of experience and knowledge.
- Do not use with a damaged cord or plug. If the machine is not working as it should, has been dropped, damaged, left outdoors or dropped in water. Make sure it is repaired by a qualified person.
- Do not pull or carry by cord, use cord as a handle, close a door on cord, or pull cord around sharp edges or corners. Do not run the machine over the cord. Keep the cord away from heated surfaces.
- Do not unplug by pulling the cord. To unplug, grasp the plug. Not the cord.
- Do not handle the plug or machine with wet hands.
- Regularly inspect the cord and plug for damage. If the cord is damaged, it must be replaced by a qualified person to avoid a hazard.
- Do not put any object into openings. Do not use any opening blocked (except during filter cleaning procedure). Keep free of dust, hair and anything that may reduce airflow.
- Keep hair, loose clothing, fingers and all parts of the body away from openings and moving parts.
- Turn off all controls before unplugging.
- Do not use it to pick up flammable or combustible liquids, such as gasoline, or use in areas where they may be present.
- Do not pick up any type of liquid.
- Do not pick up anything that is burning or smoking, such as cigarettes, matches or hot ashes.
- Use extra care when cleaning on stairs.
- Do not use without a dust bag and/or filters in place. Replace the collection system

and/or filters as described in the manual.

- If using an extension cord make sure the cord rating is suitable for this machine.
- Do not modify the machine from its original design.
- Keep children and unauthorized persons away from the machine when in use.
- All repairs must be performed by a qualified service person. Use only manufacturer-supplied or equivalent replacement parts.
- Do not expose the machine to rain or moisture. Store indoors only.
- Connect to a properly grounded outlet only. See grounding instructions.

## GROUNDING INSTRUCTION

The dust extractor must be grounded. If it should malfunction or break-down, grounding provides a path of least resistance for electric current to reduce the risk of electric shock. The dust extractor is equipped with a cord having an equipment-grounding conductor and grounding plug. The plug must be inserted into an appropriate outlet that is properly installed and grounded with all local codes and ordinances.

## SAFETY LABEL

The following label appears in front of the machine. Check all the details stated in the label before using. Replace the label if it is missing or damaged. Failure to follow this warning label may result in fire, electric shock or injury.



## 2.UNPACKING

When unpacking the machine, please check that the following accessories are included:

- ✓ Hose with 2 cuffs \* 1
- ✓ S-Wand \* 1
- ✓ Floor brush \* 1
- ✓ Reducer 70/38 \* 1
- ✓ Crevice tool \* 1
- ✓ Round brush \* 1

If any of the above-mentioned parts are missing, please contact your local distributor or our sales representative. For models that do not already have the front casters assembled due to packaging limitations. Assemble the front casters using the using bolt or nut and washer that are included in the package depending on your application. Protect the environment:

Please dispose of packaging materials and used machine components in an environmentally safe way according to local disposal regulations. Always remember to recycle.

### 3. FUNCTION

The machine is designed for vacuuming and separating dry, non-combustible dust with an explosion limit value of  $0.1\text{mg}/\text{m}^3$ .

The dust extractor is started by the switch. **All the switches can operate independently.**

Type	Models with Jet pulse filter cleaning
Switch 2 step	0: Motor off, 1: Motor on



#### Notice !!!

Before connecting the power, please confirm the voltage is consistent with the label on the machine.

- Make sure the electric plug and socket are matching
- Make sure the hose and inlet are matching
- Connect the accessories and hose end



#### Notice !!!

- Turn on the machine until the motor stop working completely.
- Please disconnect the plug when the machine doesn't work.

Dust-laden air is then sucked through the inlet valve at high speed via the suction hose. The air is slowed down by the cyclone and coarse dust particles are separated out, partly by centrifugal force and partly by gravity. Air and finer particles then pass through the double filter system where separation is made. The machine is designed for filter cleaning by reverse air pulse.

The separated dust accumulates in the cyclone until the machine is switched off, when it drops through the bottom flap into the plastic bag. The filter cleaning process is not completed before it is clear that the dust inside the tank has fallen down into the collection bag. In some extreme cases the adhesive ability of the dust must be broken manually. This can be done by hitting the dust through the bag or tapping the tank using i.e. a rubber hammer.

### 4. FILTER CLEANING

The filter must be cleaned from time to time to remain excellent suction performance. If the vacuum goes high, it means the pre-filters are blocked with a large number of dust.

#### How to do filter cleaning?

Firstly pull up the metal plate built in the air inlet to block the air inlet, the vacuum will be soon built up. Then press the jet-pulse handle for 5 seconds, and repeat this procedure for 4-5 times. We need to wait 5 seconds between every interval. Finally, push down the metal plate for air intake again.

**Please check the below chart to follow the procedure. The chart is labelled on our dust extractor.**

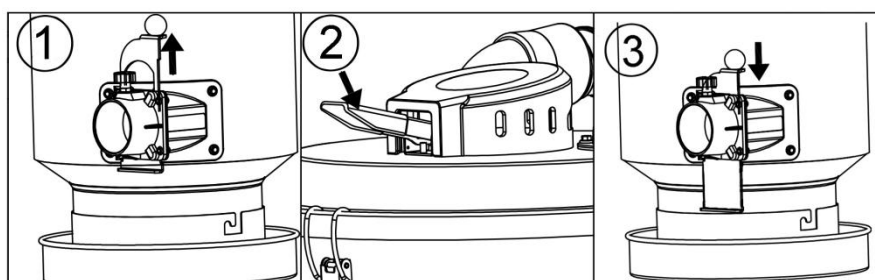

## 5. DUST COLLECTION SYSTEM

The dust collection system contains a bag holder, nylon puller strap with metal buckle, nylon ties and continuous dropping bags with a size of 357mm\*20m\*6.5decimillimeter.

**Equipping the continuous bag:** firstly unlock the bag holder, put the continuous dropping bag into the holder, tie up the bottom of the bags with nylon ties, and fasten the nylon puller strap for sealing.

**Getting rid of the dust:** while the bag is full of dust or particles, tie up the top of the bag with 2 nylon ties, and finally cut the bag between the 2 nylon ties to prevent the dust from inhaling into the lung or exposing it to the atmosphere.

**Notice:** Please remember to throw the bags into the dust bin or assigned area.

**Please check the below chart to follow the procedure. The chart is labelled on our dust extractor.**

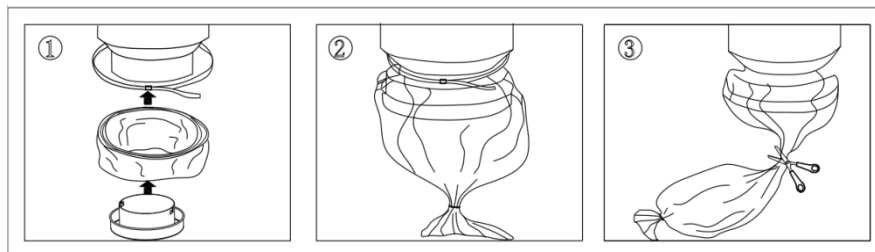

## 6. FILTER CHANGE

Risk of dust dispersion - Use personal safety equipment

Unhealthy dust can be spread during filter change. Accordingly, the user should wear protective glasses, protective gloves, and a breathing mask conforming to protection class FFP3.



### WARNING

**Remember to switch off the machine and pull the plug out of the outlet before servicing.**

#### Pre-filter

Loosen the 3 clamps and remove the top. Take the bag from the new filter.

Lift out the filter and place it gently in a plastic bag. This bag must be properly disposed.

Insert a new filter.

#### Important

If you are removing the Pre-filter to clean it. Hitting the filter with force or the use of compressed air will destroy the filter. It can handle water, but high-pressure water cleaning will destroy it.

#### HEPA Filter

Loosen the two nuts on each filter cover cap. Carefully lift the filter into a clean plastic bag, and use the bag from the new filter. This bag must be properly disposed. Insert a new filter in reverse order.

### **Important**

HEPA filters can't be cleaned, trying this might destroy it. When installing the replacement filter, make sure to not touch the inside of the filter. Any kind of force/damage on the inside of the filter media will destroy the new filter.

## **7. SERVICE**

- When cleaning and servicing the machine, you must switch off the machine and remove the plug from the outlet.
- Avoid cleaning with a high-pressure cleaner. If necessary, do not direct at the openings on the machine, especially the opening for cooling air.
- Before moving the machine from the work area, the machine must be cleaned.
- All other equipment must be regarded as contaminated and be treated thereafter.
- If possible, use a special suitable room.
- Proper personnel protective equipment must be used. Dust can be spread when the coarse filter and the absolute filter are replaced which can be hazardous to health. Accordingly, the user should wear protective glasses, protective gloves, and a breathing mask conforming to protection class FFP3.
- All parts which are contaminated after service must be properly disposed of in plastic bags according to all regulations.
- If the machine has to be used for other purposes, it is extremely important that the machine is cleaned, to avoid the spread of hazardous dust.
- Do not puncture the HEPA filter. Risk of dust dispersion.

## **8. WARRANTY**

All EVOTECH PERFORMANCE machines and accessories have a 12-month factory warranty starting from the day of purchased. Do not attempt to repair the suction apparatus without the consent of the manufacturer.

The warranty does not cover defects that are the result of normal wear and tear, negligence, defective use, unauthorized repair or the suction apparatus being connected to the incorrect voltage.

In the event of any complaint, the suction apparatus or an agreed part of it must be returned to us or our authorized representative for warranty examination and any warranty repair or replacement.



## 9. PROBLEM SOLVING

The dust extractors are designed and manufactured for severe environments and tasks, but the user must note that the machine must be protected from knocks and blows. Filter, seals, attachments, and connections are carefully adapted and selected the operator's work environment. Therefore, the operator and service personnel must treat the machine with care for it to work correctly for many years.

<b>Trouble</b>	<b>Causes</b>	<b>Solutions</b>
Motor doesn't start	No power	Plug in machine
	Cable defective	Replace cable
	Switch defective	Replace switch
Motor stops immediately after starting	Shortcut in cable/machine	Order service
Motor runs but there is no suction	Hose not connected	Connect hose
	Hose clogged/ blocked	Clean hose
	No dust collection bag	Fit dust collection system
Motor runs but poor suction	Hole in hose	Replace hose
	Filter clogged	Clean filter/ Replace filter
	Loose top cover	Adjust
	Defective gaskets	Replace affected gasket
Dust blown from motor	Wrong assembled or damaged filter system	Adjust/ Replace filter
Abnormal noise		Order service

## 10. TECHNICAL DATA

Data	Unit	EVO17
Voltage	V	230V
Power (max)	KW	1.7
	HP	2.3
Current (UL)	A	8
Airflow (max)	m <sup>3</sup> /h	217
	cfm	128
Vacuum (Max)	mbar	340
Water lift (inch)	inch	135
Main hose	Metric (mm)	5m x D38
Inlet	Metric (mm)	70
Pre filter EN 779-F8	% @1µm	99.5
Pre filter area	Metric (m <sup>2</sup> )	1.5
HEPA filter EN1833-H13	% @0.3µm	99.99
H13 HEPA filter area	Metric (m <sup>2</sup> )	1.2
Dust collection system	Type	Continuous folding bag
Dimensions (L*W*H)	Metric (mm)	430x705x1120
Weight	Metric (kg)	37

# EXPLODED VIEW EVO17

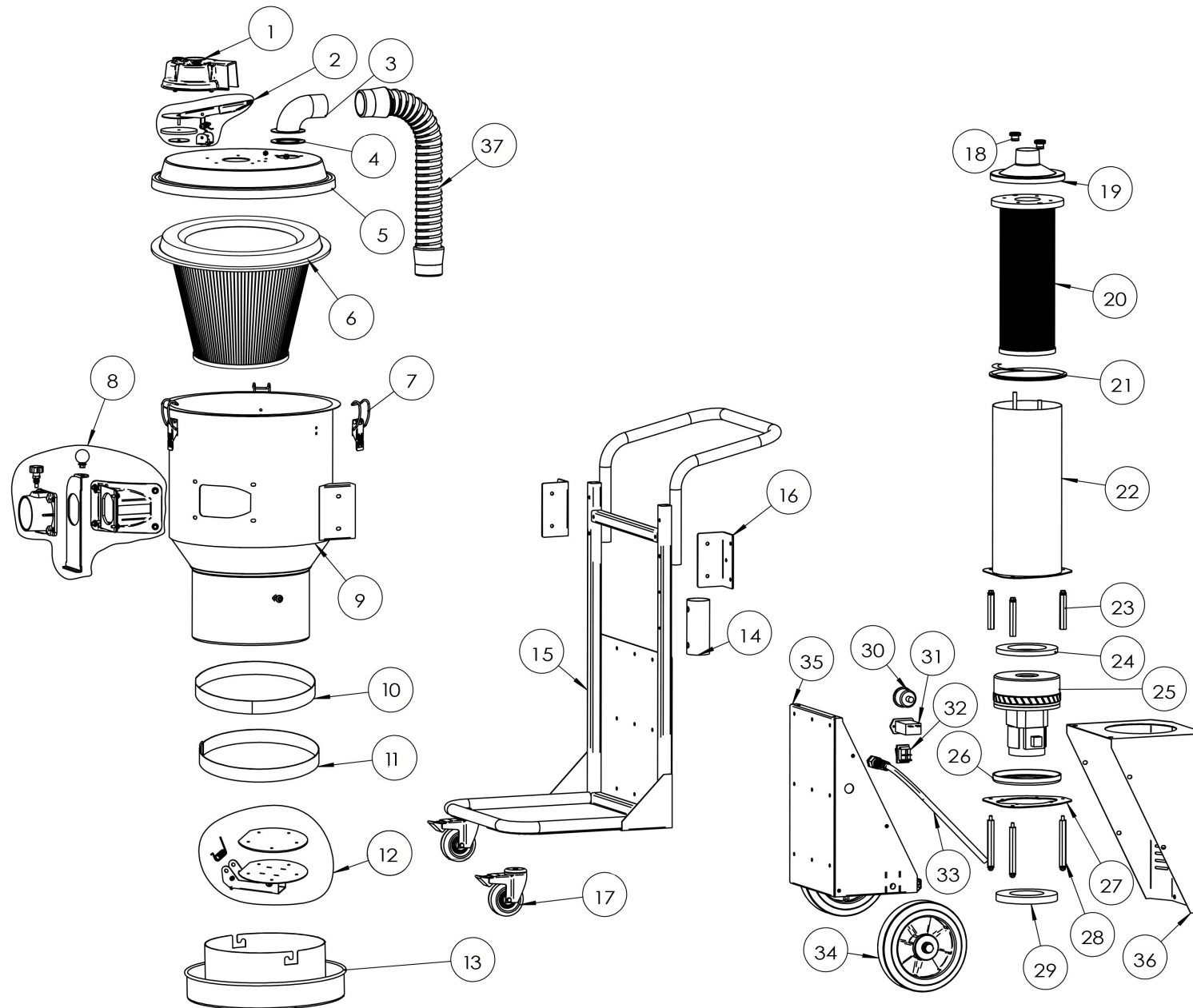

## PARTS

S/N	P/N	Description	QTY
1	D2001	Clean kits cover	1
2	BJ1001	Clean kits assembly	1
3	P1001	Elbow	1
4	D2002	Elbow sealing	1
5	BJ10021	Top cover	1
6	P1001	Pre-filter	1
7	P1002	Clamp	3
8	D1001	Air inlet assembly	1
9	BJ10021	EVO17 barrel	1
10	D3001	Foamed sealing ring	1
11	P3002	Belt	1
12	BJ1003	Flap kits assembly	1
13	BJ1004	Dropping bag holder	1
14	BJ1010	Strap holder	1
15	BJ10051	EVO17 frame	1
16	BJ1016	EVO17 Barrel fixed plate	2
17	W301	3 inch wheel	2
18	P1004	Fixed nut	2
19	BJ1011	HEPA filter cover	1
20	P2002	HEPA filter	1
21	D2005	Rubber sealing	1
22	BJ1012	Round HEPA tube	1
23	D10021	Hex nut	3

S/N	P/N	Description	QTY
24	D2006	Shock absorbing cushion	1
25	AM9877	Motor	1
26	D3002	Shock absorbing cushion	1
27	BJ1013	Motor fixed plate	1
28	D10031	Hex bolt	3
29	D30031	Sound proof sponge	1
30	DE1004	Pressure gauge	1
31	DE1003	Hour counter	1
32	DE1002	Switch	1
33	DE1001	Cable cord	1
34	W103	8 inch rear wheels	2
35	BJ10141	Motor case bottom	1
36	BJ10151	Motor case side	1
37	D20041	Hose	1